

VERTEX ILLUMINATION OF AMERICA, INC (VIA)
OR APPROVED EQUIVALENT

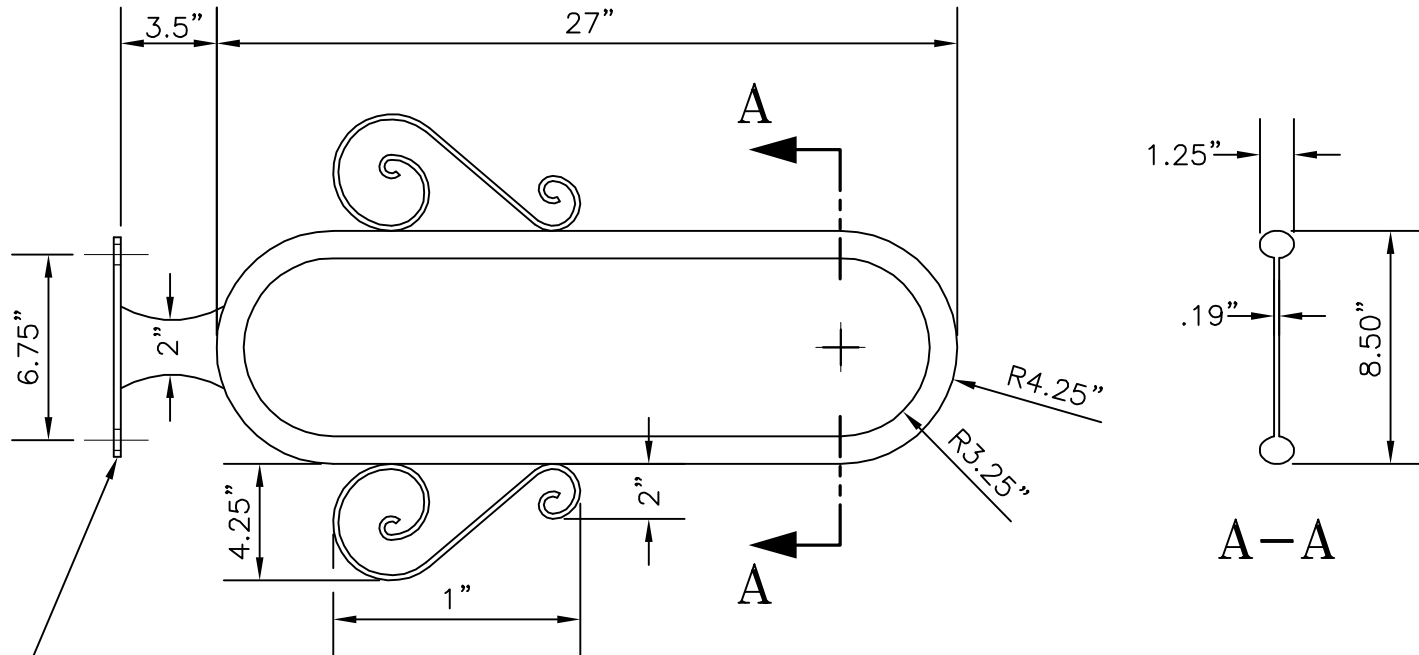

8"x2"x1/4" AL. PLATE W/
(2) .75" DIA. HOLES

CAST ALUMINUM STREET SIGN:
POWDER-COATED BLACK

NOTE:
BLUE OR GREEN SHEATHING FOR SIGN
BACKGROUND WITH WHITE REFLECTIVE LETTERING.

REVISED:
SEPT-2009

STREET LIGHTING - STREET SIGN DETAIL

STANDARD
DETAIL

ISSUED:
SEPT - 2009

CITY OF WEST PALM BEACH ENGINEERING SERVICES DEPT.

SL-12